

1. The physical basis of the heat transfer

Magnitudes, symbols, units

Temperature, temperature difference

ϑ temperature °C.....degree Celsius
 Θ thermodynamic temperature K..... Kelvin
 $\Delta\vartheta = \vartheta_2 - \vartheta_1$ temperature difference °C, K
 $\Delta\Theta = \Theta_2 - \Theta_1$ temperature difference °C, K

Temperature and temperature difference are scalar quantities. The temperature field is a scalar field. Relations between temperatures:

$$^{\circ}\text{C} + 273.15 = \text{K}$$

Heat

Qheat J..... Joule

Heat is a form of energy. Relations between units:

jednotka	J	Wh	cal	kpm	erg
J	1	$2.778 \cdot 10^{-4}$	0.239	0.102	10^7
Wh	3600	1	860	367.1	$3.6 \cdot 10^{10}$
cal	4.186	$1.163 \cdot 10^{-3}$	1	0.427	$4.186 \cdot 10^7$
kpm	9.807	$2.724 \cdot 10^{-3}$	2.343	1	$9.807 \cdot 10^7$
erg	10^{-7}	$2.778 \cdot 10^{-11}$	$2.389 \cdot 10^{-8}$	$1.020 \cdot 10^{-8}$	1

Thermal capacity (stored heat)

$$Q = m \cdot c \cdot \Delta\vartheta \quad (\text{J; kg, J.kg}^{-1} \cdot \text{K}^{-1}, \text{K})$$

m weight
 c specific thermal capacity
 $\Delta\vartheta$ temperature difference

Specific thermal capacity

c specific thermal capacity ($\text{J.kg}^{-1} \cdot \text{K}^{-1}$)

Relations between units:

jednotka	$\text{J.kg}^{-1} \cdot \text{K}^{-1}$	$\text{kJ.kg}^{-1} \cdot \text{K}^{-1}$	$\text{cal.kg}^{-1} \cdot \text{K}^{-1}$	$\text{kcal.kg}^{-1} \cdot \text{K}^{-1}$
$\text{J.kg}^{-1} \cdot \text{K}^{-1}$	1	10^{-3}	0.2389	$0.2389 \cdot 10^{-3}$
$\text{kJ.kg}^{-1} \cdot \text{K}^{-1}$	10^3	1	238.9	0.2389
$\text{cal.kg}^{-1} \cdot \text{K}^{-1}$	4.186	$4.186 \cdot 10^{-3}$	1	10^{-3}
$\text{kcal.kg}^{-1} \cdot \text{K}^{-1}$	4186	4.186	10^3	1

Thermal power

Thermal power is the heat per unit of time. It is scalar.

P thermal power W.....watt

Heat flow density

Heat flow density is the thermal power per unit area. It is vector - its direction is the normal to the considered surface element dA .

qheat flow density $W \cdot m^{-2}$ watt per square meter

$$q = dP/dA$$

Example 1) How many kcal/hour is 10 W?

Answer: $10 \text{ (W)} = 10 \text{ (J/s)} = 10 \cdot 3600 / 4186 \text{ (kcal/hour)} = 8.6 \text{ (kcal/hour)}$

Example 2) How much cal corresponds to 5 Wh?

$$5 \text{ (Wh)} = 5/3600 \text{ (W.s)} = 5/3600 \cdot \text{cal} / 4.186 = 4300 \text{ cal}$$

Example 3) What will be the specific resistance of aluminum in Ω/m , if in the $\Omega \cdot mm^2/m$ equal to the value 0.03? $(3 \cdot 10^{-8} \Omega \cdot m)$

Example 4) What will be the current density in A/m^2 , when A/mm^2 equal to 5? $(5 \cdot 10^6 A/m^2)$

Example 5) How many kpm corresponds to a value of 3 cal? (1.278 kpm)

Relation between thermal and mechanical energy

For practice is good to perceive to how many mechanical work respond of thermal energy amounting to one kilocalorie. This documented by the following examples:

Example 1)

How much cement could be loaded on a 2 m high lorry by the energy required to heat 1 liter of water by 20 °C? Loading efficiency is $\eta =$ **a)** 100% **b)** 50%.

Answer:

Required thermal energy:

$$Q = m \cdot c \cdot \Delta\vartheta = 1 \cdot 4.186 \cdot 10^3 \cdot 20 = 8.372 \cdot 10^4 \text{ J}$$

The energy required for loading:

$$W = mgh/\eta \quad g \dots \text{gravity acceleration}$$

$$h \dots \text{loading height}$$

$$\eta \dots \text{loading efficiency}$$

From the equality $Q = W$ we determine the weight of the load

$$\mathbf{a)} \quad m = Q \cdot \eta / (g \cdot h) = 83\,720 \cdot 1 / (2 \cdot 9.806) = 4\,267 \text{ kg}$$

$$\mathbf{b)} \quad m = 83\,720 \cdot 0.5 / (2 \cdot 9.806) = 2\,134 \text{ kg}$$

The results indicate that the energy required to brew multiple cups of tea would be enough for loading several tens of cents cement to truck or wagon.

Example 2)

How many times is the more energy intensive liter of warm tap water than a liter of cold tap water. Both water is drawn from the same source of temperature $\vartheta_1 = 10^\circ \text{C}$ to a height $h = 100 \text{ m}$. Cold water is taken directly in the place of consumption, hot water is heated in the place of consumption to $\vartheta_2 = 70^\circ \text{C}$.

Pumping efficiency of pump with an electric motor considering in relation to primary energy $\eta_p = 0.15$ (η of power plant = 0.3, η of motor with pump = 0.5). We are considering heating by coal with efficiency $\eta_h = 0.5$.

Answer:

The energy needed for cold water (relate to 1 liter)

$$W_c = mgh/\eta_p = 1 \cdot 9.806 \cdot 100 / 0.15 = 6538 \text{ J}$$

The energy needed for hot water (relate to 1 liter)

$$W_w = mgh/\eta_p + mc\Delta(\vartheta_2 - \vartheta_1)/\eta_h$$

$$W_w = 1 \cdot 9.806 \cdot 100 / 0.15 + 1 \cdot 4186 \cdot (70 - 10) / 0.5 = 6538 + 502320$$

$$= 508858 \text{ J}$$

$$n = W_w / W_c = 508858 / 6538 = 77.8$$

Warm water is almost 78 times more energy intensive than cold water.

Example 3)

What input power would have to have direct electric flow heater to warm water flowing from the tap with a diameter of 10 mm have the parameters $\vartheta_2 = 60^\circ \text{C}$ and speed $v = 2 \text{ m/s}$? Heating efficiency is 97%. How much fluorescent lamp with power input 40 W could shine with this input power? (33.5 kW, 838 lamps)

Example 4)

How many times more energy needed to heat the 10 liters of water of 10°C , than to the lift up this 10 liters of water to height 10 m? Heating efficiency and lifting efficiency we consider 100%. (427 times)

Example 5)

How many $^\circ \text{C}$ warmed water at 200 meters high waterfalls, if all its potential energy is converted into heat? From which the height would have to fall water at 0°C to cook? (0.47°C , 42692 m)

Example 6)

Tub is filled with 100 liters warm water with temperature 37°C which was heated from 10°C . How high we had to bring this water to potential energy of water is equal to the energy required for the heating process? Heating efficiency is equal lifting efficiency. (11527 m)

Example 7)

How many $^\circ \text{C}$ will 20 liters of water heats by energy of 1 kWh with heating efficiency of 90%. How many people weighing 80 kg will with energy of 1 kWh transport by lift from the ground floor to the fifth floor (23 meters) with lifting efficiency 60%? (38.7°C , 120 people)

Heat transfer by conduction

There are three ways of heat transfer, either single or more often their various combinations:

- 1) conduction
- 2) convection
- 3) radiation

For heat transfer by conduction define the thermal conductivity coefficient λ as a material constant characterizing the ability of the substance to transmit heat by conduction (this capability is directly proportional to the size of the coefficient). Unit of the thermal conductivity is $\text{W} \cdot \text{m}^{-1} \cdot \text{K}^{-1}$.

For the thermal conduction following relation holds:

$$P = \int_S \bar{q} \cdot d\bar{S} = \int_S -\lambda \cdot \text{grad}\Theta d\bar{S}$$

which for homogeneous temperature relationship goes into form:

$$P = \lambda \cdot \frac{S}{l} \cdot \Delta\vartheta \quad (\text{W} ; \text{W} \cdot \text{m}^{-1} \cdot \text{K}^{-1}, \text{m}^2, \text{m}, \text{K})$$

Example 1) Plane wall

Determine thermal power through a wall with thickness $l = 50 \text{ mm}$ and surface $S = 1 \text{ m}^2$. The temperature on the outer surface of the wall is $\vartheta_1 = 100 \text{ }^\circ\text{C}$, on the inner surface $\vartheta_2 = 90 \text{ }^\circ\text{C}$. The wall is:

- a) of steel, $\lambda = 40 \text{ W} \cdot \text{m}^{-1} \cdot \text{K}^{-1}$
- b) of concrete, $\lambda = 1.1 \text{ W} \cdot \text{m}^{-1} \cdot \text{K}^{-1}$
- c) of diatomite $\lambda = 0.11 \text{ W} \cdot \text{m}^{-1} \cdot \text{K}^{-1}$

Answer:

$$P = \lambda \cdot \frac{S}{l} \cdot \Delta\vartheta$$

$$\text{a) } P = 40 \cdot \frac{1}{0.05} \cdot (100 - 90) = 8000 \text{ W}$$

$$\text{b) } P = 1.1 \cdot \frac{1}{0.05} \cdot (100 - 90) = 220 \text{ W}$$

$$\text{c) } P = 0.11 \cdot \frac{1}{0.05} \cdot (100 - 90) = 22 \text{ W}$$

Example 2) Composite plane wall

Determine the heat flow through the wall of the boiler. The wall is covered with a layer of carbon black with parameters $l_1 = 1 \text{ mm}$, $\lambda_1 = 0.08 \text{ W} \cdot \text{m}^{-1} \cdot \text{K}^{-1}$ and from side with water is layer of boiler scale with parameters $l_3 = 2 \text{ mm}$, $\lambda_3 = 0.8 \text{ W} \cdot \text{m}^{-1} \cdot \text{K}^{-1}$. The wall of boiler has parameters $l_2 = 12 \text{ mm}$, $\lambda_2 = 50 \text{ W} \cdot \text{m}^{-1} \cdot \text{K}^{-1}$. The wall temperature at the water side is $\vartheta_4 = 206 \text{ }^\circ\text{C}$, on the side of heating is $\vartheta_1 = 685 \text{ }^\circ\text{C}$. Determine the density of heat flow q , the temperature at the interface of layers, the mean temperature of layers. The wall of the boiler has a surface area $S = 10 \text{ m}^2$.

Answer:

Density of heat flow:

$$q = \frac{\vartheta_1 - \vartheta_4}{\frac{l_1}{\lambda_1} + \frac{l_2}{\lambda_2} + \frac{l_3}{\lambda_3}} = \frac{685 - 206}{\frac{0.001}{0.08} + \frac{0.012}{50} + \frac{0.002}{0.8}} = 31430 \text{ W} \cdot \text{m}^{-2}$$

The temperature at the interface:

Carbon black – boiler

$$\vartheta_2 = \vartheta_1 - q \cdot \frac{l_1}{\lambda_1} = 685 - 31430 \cdot \frac{0.001}{0.08} = 292.12^\circ\text{C}$$

Boiler scale – boiler

$$\vartheta_3 = \vartheta_4 + q \cdot \frac{l_3}{\lambda_3} = 206 + 31430 \cdot \frac{0.002}{0.8} = 284.58^\circ\text{C}$$

The mean temperature of layers:

Carbon black

$$\vartheta_{cb} = \frac{\vartheta_1 + \vartheta_2}{2} = \frac{685 + 292.12}{2} = 488.56^\circ\text{C}$$

Wall of boiler

$$\vartheta_{wb} = \frac{\vartheta_2 + \vartheta_3}{2} = \frac{292.12 + 284.56}{2} = 288.35^\circ\text{C}$$

Boiler scale

$$\vartheta_{bs} = \frac{\vartheta_3 + \vartheta_4}{2} = \frac{284.58 + 206}{2} = 245.29^\circ\text{C}$$

Heat flow:

$$P = q \cdot S = 31430 \cdot 10 = 3.143 \cdot 10^5 \text{ W}$$

Example 4) Cylindrical wall

Determine density of heat flow q ($\text{W} \cdot \text{m}^{-1}$) through the wall of refractory steel tubes with dimensions $d_1 = 32$ mm, $d_2 = 42$ mm. Thermal conductivity of the material from which the tube is made $\lambda = 14$ $\text{W} \cdot \text{m}^{-1} \cdot \text{K}^{-1}$. The temperature outside of the pipe $\vartheta_1 = 580$ °C, the temperature of the inner wall of the tube $\vartheta_2 = 450$ °C.

Answer:

For composite cylindrical wall is for heat conduction relation:

$$q = \frac{2 \cdot \pi \cdot \Delta \vartheta}{\sum_{i=1}^n \frac{1}{\lambda_i} \cdot \ln \frac{d_{i+1}}{d_i}} \quad (\text{W} \cdot \text{m}^{-1}; \text{K}, \text{W} \cdot \text{m}^{-1} \cdot \text{K}^{-1}, \text{m})$$

For single-layer wall and our values

$$q = \frac{2 \cdot \pi \cdot (580 - 450)}{\frac{1}{14} \cdot \ln \frac{42}{32}} = 42052 \text{ W} \cdot \text{m}^{-1}$$

Heat transfer by convection

We introduce the heat transfer coefficient α with unit $\text{W}\cdot\text{m}^{-2}\cdot\text{K}^{-1}$ which determines how large heat flow (power) flows through a unit area during a temperature difference of 1°C . This heat transfer is applied in the transfer from a solid surface to the ambient area or vice versa (usually in combination with radiation).

Heat transfer by convection is one of the most difficult computational problems in heating technology. In important cases is best, if we determine the heat transfer coefficient α by measuring ourselves on model matching that of our case using the following relations in which they occur α :

For heat transfer by convection apply Newtons Law:

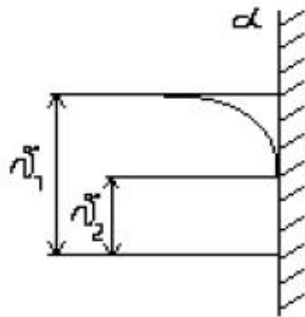

$$P = \alpha \cdot S \cdot \Delta\vartheta \quad (\text{W}; \text{W}\cdot\text{m}^{-2}\cdot\text{K}^{-1}, \text{m}^2, \text{K})$$

Example 1) Heat transfer only by convection

Determine the heat loss of the vertical wall with surface $S = 1 \text{ m}^2$. Wall temperature $\vartheta_1 = 60^\circ\text{C}$, ambient temperature $\vartheta_2 = 10^\circ\text{C}$.

- a) natural convection $\alpha = 4 \cdot (\Delta\vartheta)^{0,13}$, $v_0 = 0 \text{ m}\cdot\text{s}^{-1}$
 b) by blowing $\alpha = 5,8 + 3,95 \cdot v_0$, $v_0 = 5 \text{ m}\cdot\text{s}^{-1}$
 v_0 is the flow velocity of the medium by the wall

Answer:

$$\begin{aligned} \text{a)} \quad P &= \alpha \cdot S \cdot \Delta\vartheta = 4 \cdot (\Delta\vartheta)^{0,13} \cdot S \cdot \Delta\vartheta = \\ &= 4 \cdot (60 - 10)^{0,13} \cdot 1 \cdot (60 - 10) = 332,6 \text{ W} \end{aligned}$$

$$\begin{aligned} \text{b)} \quad P &= \alpha \cdot S \cdot \Delta\vartheta = (5,8 + 3,95 \cdot v_0) \cdot S \cdot \Delta\vartheta = \\ &= (5,8 + 3,95 \cdot 5) \cdot 1 \cdot (60 - 10) = 1277,5 \text{ W} \end{aligned}$$

Example 2)

Determine graphically the course of temperature in the room wall. Internal temperature $\vartheta_1 = 20^\circ\text{C}$, external temperature $\vartheta_5 = -20^\circ\text{C}$. The inner wall is brick with thickness $s_1 = 0,36 \text{ m}$, thermal conductivity coefficient $\lambda_1 = 0,464 \text{ W}\cdot\text{m}^{-1}\cdot\text{K}^{-1}$, further is the layer of concrete with thickness $s_2 = 0,13 \text{ m}$, thermal conductivity coefficient $\lambda_2 = 1,102 \text{ W}\cdot\text{m}^{-1}\cdot\text{K}^{-1}$. Heat transfer coefficient on the inner surface $\alpha_2 = 17,4 \text{ W}\cdot\text{m}^{-2}\cdot\text{K}^{-1}$, heat transfer coefficient on the outer surface $\alpha_1 = 5,8 \text{ W}\cdot\text{m}^{-2}\cdot\text{K}^{-1}$.

Answer:

- 1) We draw a cross-sectional view of the composite wall, which permeates the heat flow.

- 2) On the vertical axis mark the indoor and outdoor temperature.
- 3) At the level of internal temperature, we draw the pole P right to the wall.
- 4) Calculate the unit thermal resistances corresponding to the mode of heat transfer and the supplied parameters.
- 5) To the vertical halfline at an arbitrary point between the pole P and the composite wall will of levels of internal temperature toward the level of the outside temperature gradually scale unit applied thermal resistances:
 - convection on the inner side of the composite wall
 - conduction through layer of bricks
 - conduction through layer of concrete
 - convection on the outer side of the composite wall
- 6) We connect the pole P with the end of thus rendered thermal resistances.
- 7) At the point where we connector of pole with the end point of the last heat resistance crosses the outside temperature, we construct halfline vertically.
- 8) Intersections of pole connectors with endpoints of unit thermal resistances thus constructed halfline we indicate temperature at the interfaces of individual layers:
 - on the inner side of the composite layer
 - at the interface of two layers of the composite wall
 - on the outer side of the composite wall
- 9) We bring these temperatures into the corresponding places of the composite wall.
- 10) By connection of these temperatures reach the desired graphical representation of the temperature.

Calculation of unit thermal resistances:

- convection on the inner side of the composite wall

$$R_{q1} = \frac{1}{\alpha_2} = \frac{1}{17,4} = 0,0575 \text{ W}^{-1} \cdot \text{K}$$

- conduction through layer of bricks

$$R_{q2} = \frac{s_1}{\lambda_1} = \frac{0,36}{0,464} = 0,776 \text{ W}^{-1} \cdot \text{K}$$

- conduction through layer of concrete

$$R_{q3} = \frac{s_2}{\lambda_2} = \frac{0,13}{1,102} = 0,118 \text{ W}^{-1} \cdot \text{K}$$

- convection on the outer side of the composite wall

$$R_{q4} = \frac{1}{\alpha_1} = \frac{1}{5,8} = 0,172 \text{ W}^{-1} \cdot \text{K}$$

Graphic construction

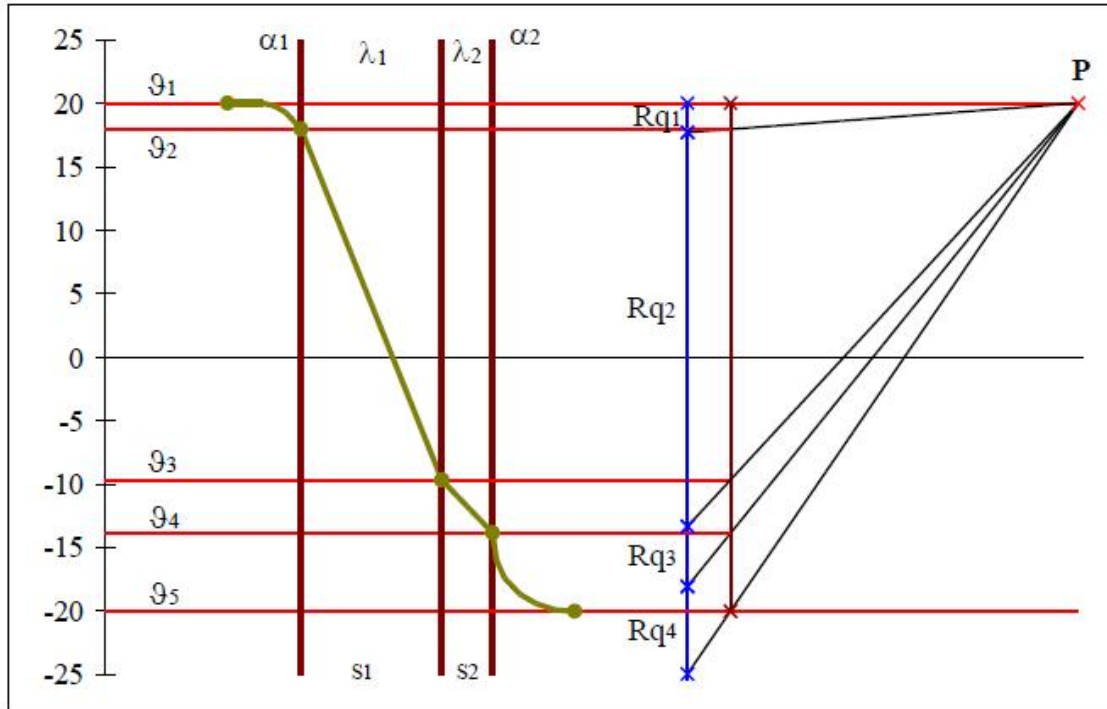

Heat transfer by radiation

Every object whose temperature is above 0 K, it radiates heat energy from its surface. It is electromagnetic waves, which are governed by the laws of geometrical optics.

Laws governing the transfer of heat by radiation:

a) Stefan-Boltzmann law

$$P_b = \sigma_b \cdot \Theta^4 \quad (W \cdot m^{-2}; W \cdot m^{-2} \cdot (K/100)^{-4}, K/100)$$

$$\text{Stefan-Boltzmann constant } \sigma_b = 5.6697 W \cdot m^{-2} \cdot (K/100)^{-4}$$

b) Planck law

$$M_{\lambda b} = f(\Theta, \lambda) = \frac{c_1}{\lambda^5 \cdot \left(e^{\frac{c_2}{\lambda \cdot \Theta}} - 1 \right)} \quad (W \cdot m^{-4}; m, K)$$

$$\text{Planck constants } c_1 = 3.73 \cdot 10^{-16} W \cdot m^2$$

$$c_2 = 1.438 \cdot 10^{-2} m \cdot K$$

c) Wien's law

$$\lambda_m = \frac{2892}{\Theta} \quad (\mu m; K)$$

d) Thermal power being passed to two parallel, equally large areas. Each with area A , one has temperature Θ_1 and emissivity ε_1 and second has temperature Θ_2 and emissivity ε_2 :

$$P = \frac{A \cdot \sigma_b}{\frac{1}{\varepsilon_1} + \frac{1}{\varepsilon_2} - 1} \cdot \left[\left(\frac{\Theta_1}{100} \right)^4 - \left(\frac{\Theta_2}{100} \right)^4 \right] \quad (W)$$

e) Two areas, where A_2 spatially completely surrounds the smaller A_1 :

$$P = \frac{A_1 \cdot \sigma_b}{\frac{1}{\varepsilon_1} + \frac{A_1}{A_2} \cdot \left(\frac{1}{\varepsilon_2} - 1 \right)} \cdot \left[\left(\frac{\Theta_1}{100} \right)^4 - \left(\frac{\Theta_2}{100} \right)^4 \right] \quad (W)$$

Example 1)

Determine P_b , λ_m , $M_{\lambda mb}$ absolutely black body of area $S = 300 \text{ cm}^2$ and temperature $\vartheta = 1200^\circ\text{C}$.

Answer:

Heat flow (power):

$$P_b = \sigma_b \cdot \Theta^4 \cdot S = 5.6697 \cdot \left(\frac{1200 + 273.15}{100} \right)^4 \cdot 300 \cdot 10^{-4} = 8000 W$$

A wavelength at which is the maximum of the spectral density of the intensity:

$$\lambda_m = \frac{2892}{\Theta} = \frac{2892}{(1200 + 273.15)} = 1.96 \mu m$$

The spectral density of the intensity of radiation at a wavelength $1.96 \mu m$:

$$M_{\lambda mb} = f(\Theta, \lambda) = \frac{c_1}{\lambda_m^5 \cdot \left(e^{\frac{c_2}{\lambda_m \cdot \Theta}} - 1 \right)} = \frac{3.73 \cdot 10^{-16}}{\left(1.96 \cdot 10^{-6} \right)^5 \cdot \left(e^{\frac{1.438 \cdot 10^{-2}}{1.96 \cdot 10^{-6} \cdot 1473.15}} - 1 \right)} = 8.9 \cdot 10^{10} W \cdot m^{-3}$$

Example 2)

Determine the thermal power radiated from the body with area $A_1 = 1 \text{ cm}^2$, temperature $\vartheta_1 = 1000 \text{ }^\circ\text{C}$, emissivity $\varepsilon_1 = 0.9$ to body with area $A_2 = 10 \text{ cm}^2$, temperature $\vartheta_2 = 0 \text{ }^\circ\text{C}$, emissivity $\varepsilon_2 = 0.9$. A second body spatially completely surrounds the first body.

Answer:

$$P = \frac{A_1 \cdot \sigma_b}{\frac{1}{\varepsilon_1} + \frac{A_1}{A_2} \cdot \left(\frac{1}{\varepsilon_2} - 1 \right)} \cdot \left[\left(\frac{\Theta_1}{100} \right)^4 - \left(\frac{\Theta_2}{100} \right)^4 \right]$$

$$P = \frac{1 \cdot 10^{-4} \cdot 5.67}{\frac{1}{0.9} + \frac{1}{10} \cdot \left(\frac{1}{0.9} - 1 \right)} \cdot \left[\left(\frac{1273.15}{100} \right)^4 - \left(\frac{273}{100} \right)^4 \right] = 13.25 W$$